

TYPE

TFC/AN

Frese cilindriche elica 45° tagliente al centro
Twist-end milling tools, 45° center cutting

metallo duro Grana Extrafine. < 0,5µ

Grain Extrafine ordered. < 0,5 µ

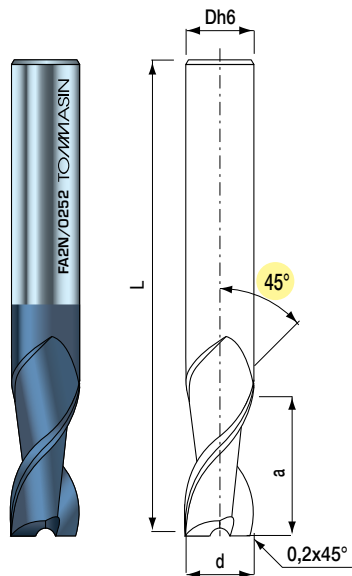
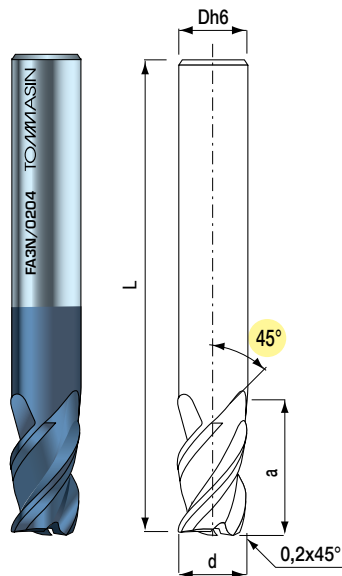
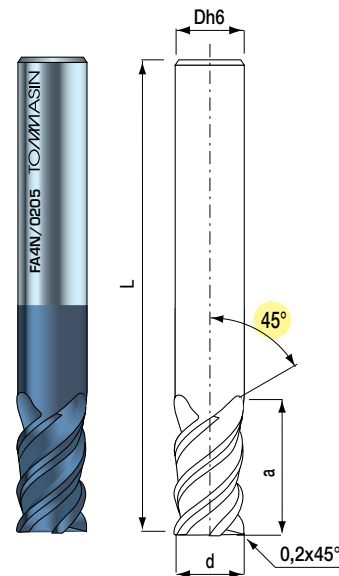
FA2Nart. **0252-Z2****FA3N**art. **0204-Z3****FA4N**art. **0205-Z4**

STANDARD

d=D	L	a
*4,0	50	8
6,0	57	10
8,0	63	16
10,0	70	20
12,0	73	22
14,0	75	22
16,0	82	26

ricopertura TiAlN
coating TiAlN

* = a richiesta
 on request