

art. **0034**

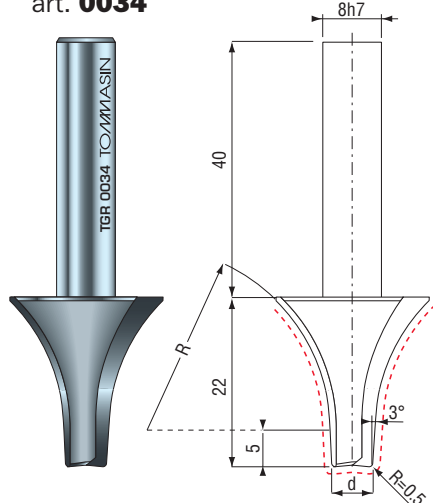

art. **0187**

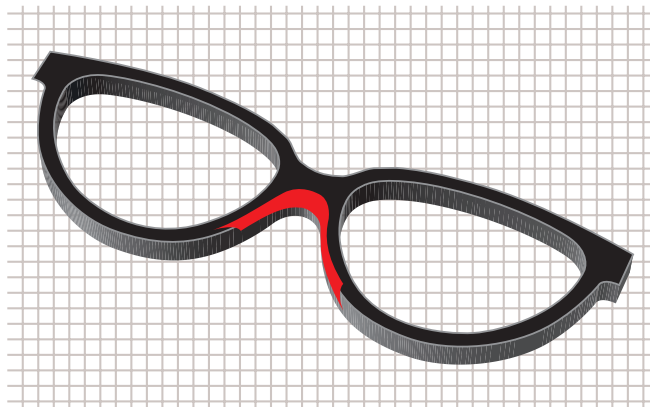
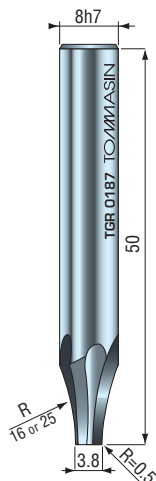

STANDARD

R	16	25
d	5	5 or 7.3

Frese per raggiare esternamente e raccordare naselli
 10.000 ÷ 18.000 R.P.M.
 Cutters for external rounding and joint of bridge.

art. **0125**

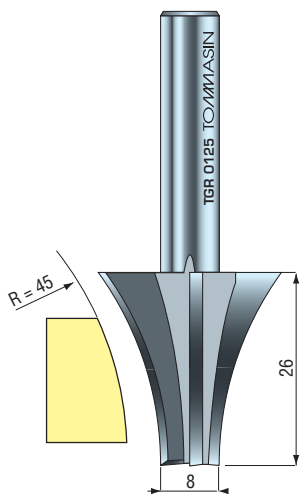

art. **0125/A**

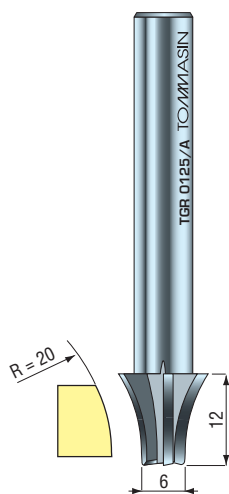

art. **0125/B**

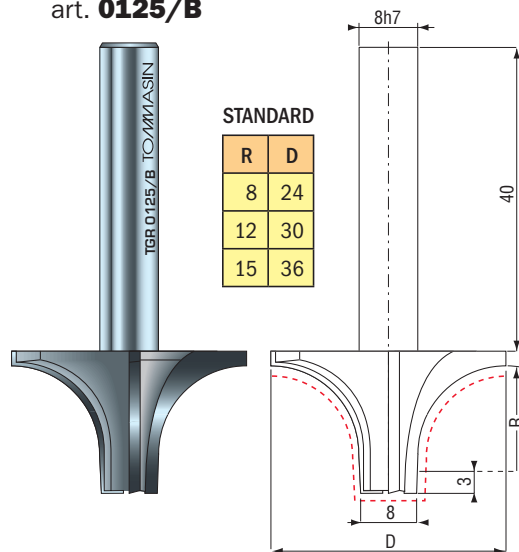

STANDARD

R	D
8	24
12	30
15	36

art. **0094**

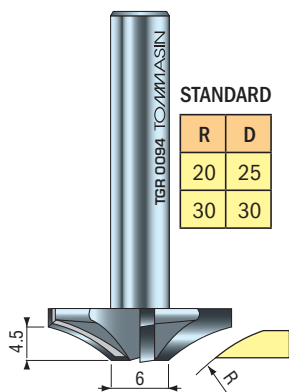

STANDARD

R	D
20	25
30	30

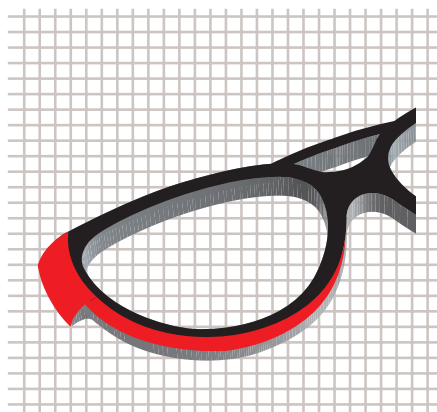

*art. **0059**

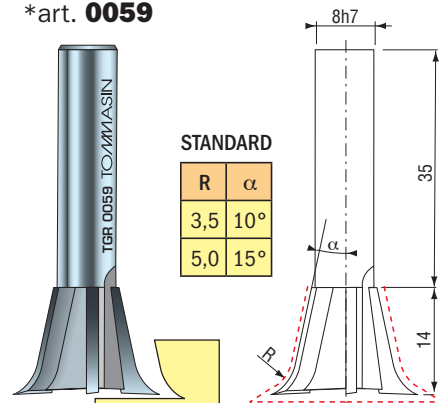

STANDARD

R	alpha
3,5	10°
5,0	15°

Frese per musi incollati. - Cutter for glued lugs.

* = a richiesta - on request