

art. **0051**

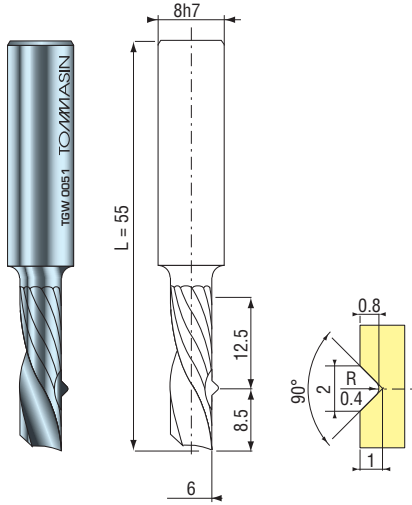

art. **0051/A**

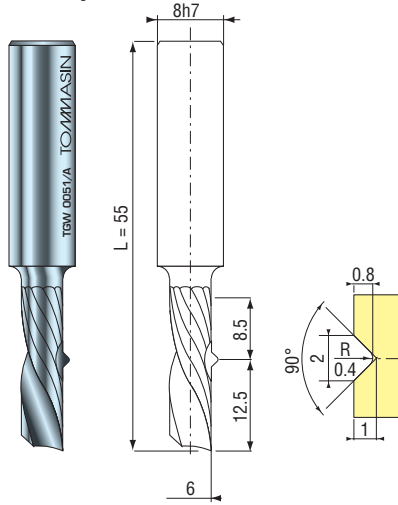

art. **0151**

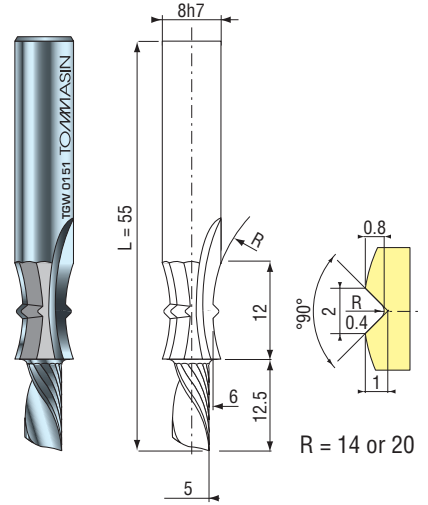

art. **0053**

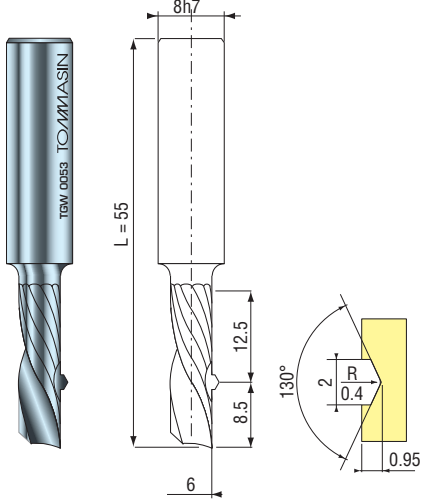

art. **0053/A**

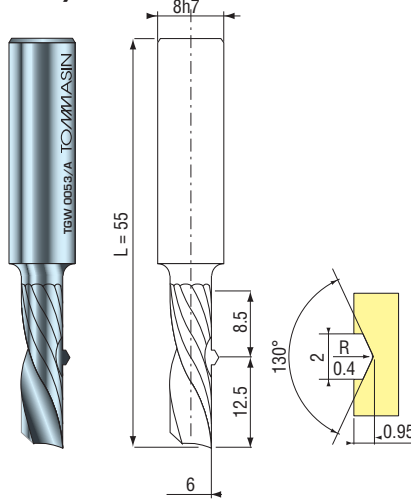

art. **0173**

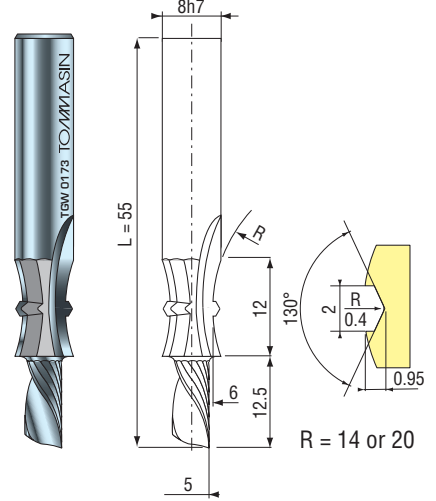

*art. **0051/R**

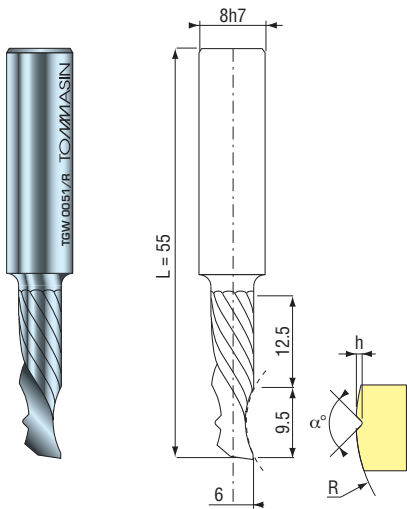

art. **0053/B**

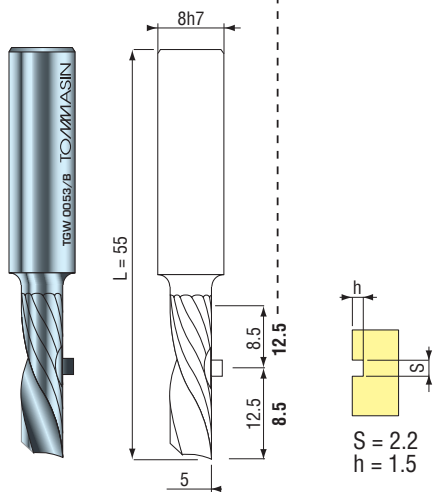

art. **0053/C**

S = 2.2
h = 1.5

*art. **0154**

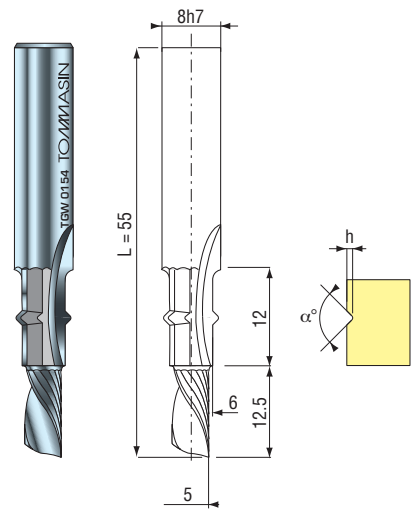

* = a richiesta - on request

art. **0054**

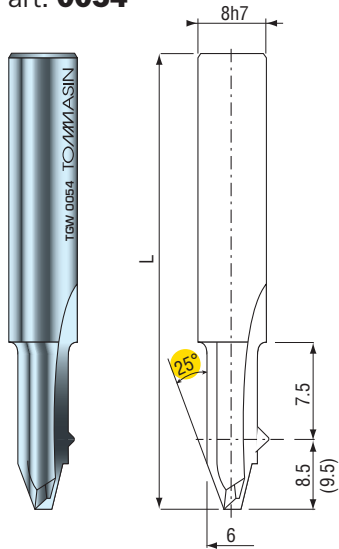

*art. **0013**

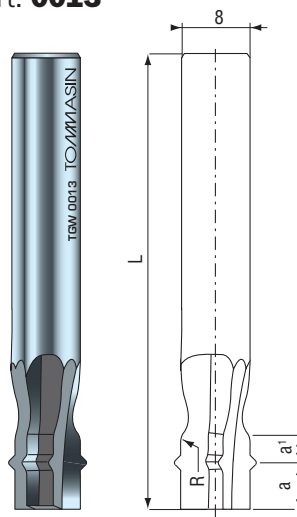

*art. **0014**

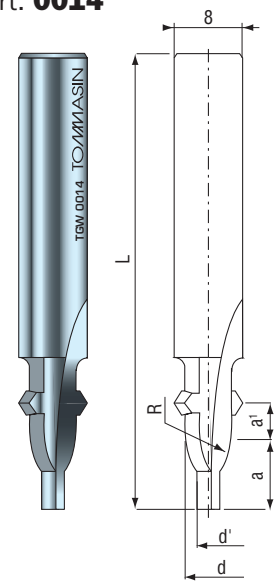

*art. **0052**

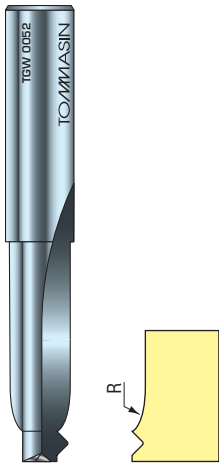

Per fresatura alette sottosquadra.
For milling lugs.

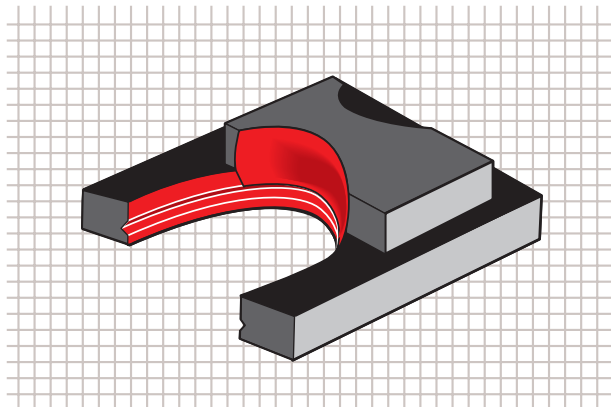

canalino vista
eyewear lens groove

A

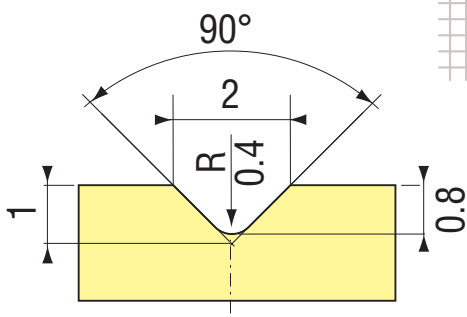

canalino sole
sunglasses lens groove

B

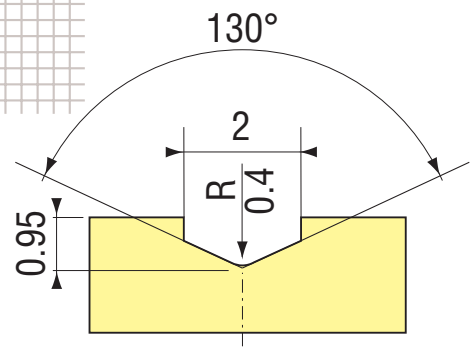

Tutti i tipi di fresa per interni,
 sono disponibili a magazzino;
 sia per il profilo canalino "A"
 che per il profilo canalino "B".

*Both groove types "A" and "B"
 are available on stock.*